

## COMMUTATION AND CONTROL

### RELAYS

REFERENCE has been made in previous sections to a need for control. Even though a clutch has mechanical control over the operation of a mechanism, the clutch itself requires electrical control. In addition to clutches there are many other mechanisms which require electrical control.

One device used to provide the necessary control is a relay. A relay is an electromagnetic device used to complete or open electrical circuits. There are many types of relays in use in present IBM machines, but one of the most common is the duo relay.

#### Duo Relay

The term duo, meaning two, was applied to relays when two coils were wound on one core. The relay could then take the place of two relays because a separate pick coil could be in two separate circuits, each with its own control, or a second circuit could be used to hold the relay energized. However, today the term duo-relay includes all relays which are built on the type frame shown in Figure 93. The term no longer has a meaning either as to the number of coils found on the relay or the number of points which are stacked on it. However, a duo relay does, as a general rule, provide simultaneous control over sev-

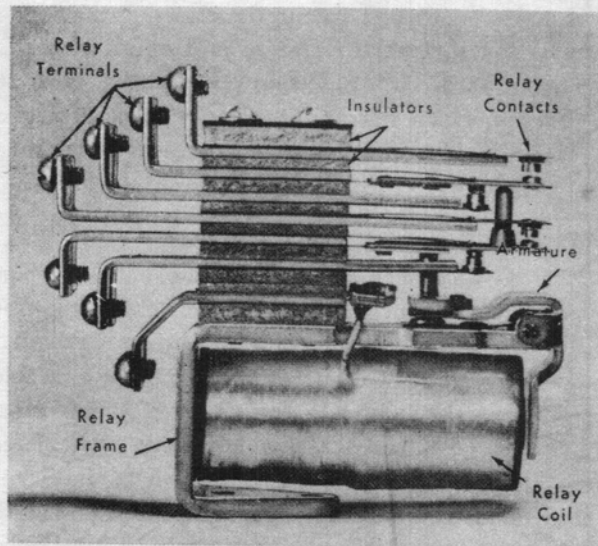

Figure 93. Duo Relay

eral circuits because of the number of points possible on the relay. It is available in a wide range of operating speeds, contact point combinations, and coil combinations in IBM machines.

There may be several contacts stacked on a duo relay, but each one can be classified according to type. Contacts which are closed when the relay is not energized (no outside force is acting upon them), are referred to as normally closed contacts (N/C). Those which are open are referred to as normally open (N/O). Some are transfer contacts which have both a N/C side and a N/O side. Figure 94 shows the three most common types of contacts found on a duo relay, and their electrical symbols. It also shows that an individual contact point on a relay may be referred to as the N/O point, N/C point, or operating point (O/P) to better identify the point involved.

Duo relay contacts are usually arranged in two piles. Looking at the armature end of the relay, the A side

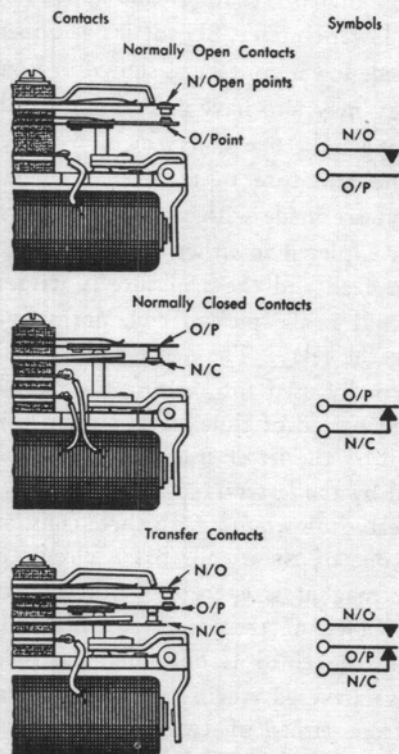

Figure 94. Duo Relay Contacts and Symbols

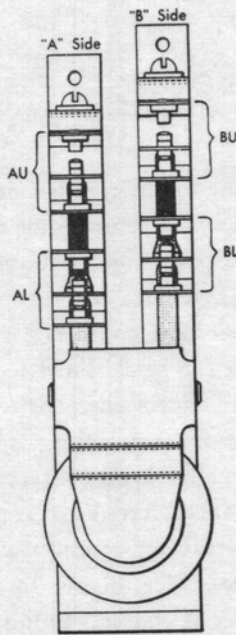

Figure 95. Duo Relay Contact Identification

is the left pile and the *B* side is the right pile on all machines except the 285 and 601. There are often two sets of contacts on one of the two sides or on both sides. To facilitate the identification of a contact, they are designated AU for *A* side upper contact, AL for *A* side lower contact, BU for *B* side upper contact, BL for *B* side lower contact as shown in Figure 95.

The relay may also have several coil combinations. It may have only one coil which, when energized, attracts the armature to transfer the relay points. Some relays are made with two coils and whenever a circuit is completed to either of these coils, the magnet is energized and the armature is attracted. One of these coils is the pickup coil, normally used for energizing the relay. The other coil is the hold coil, and is normally used for keeping the relay energized for a given period of time. The pickup coils will be referred to by the letter *P* and the hold coils will be designated by the letter *H*.

Some relays are wound with three coils, and whenever any one of these coils has a circuit completed to it, the magnet is energized and the armature is attracted. Two of these coils are normally pickup coils while the third is normally the holding coil. Such relays are used where it is necessary to energize a relay from either of two separate circuits. The pickup coils are identified in that one of the coils is

known as the pickup upper (*PU*), and the other is the pickup lower (*PL*). These terms refer to the position of the terminals and not to the position of the winding on the relay as this may vary between assemblies.

All relays which use two or three coils must have these coils correctly polarized when they are connected. The wires to the coils must be connected so that the magnetic polarity of all coils is in the same direction. If the pickup and hold coils do not have the same polarity, the magnetic fields of these coils will be opposed and the relay may fail to hold. In general the *B* side of the relay coils is the common side and is connected to a fuse. Figure 96 shows the three common combinations of relay coils.

It should also be recognized that *use* is *not* the only difference between the pickup and hold coils. There is a difference in construction as well. A pickup coil is designed to pick a coil rapidly but is not generally capable of passing current for sustained periods of time without overheating and burning out. However, because the primary use of the hold coil is to hold the relay energized for longer periods of time, it is designed for this purpose. It is wound with finer wire and more turns which increases the resistance but also decreases the current. As a result, the power used, or heat generated, will be less. For this reason the coil can be energized for greater periods of time. However, relays picked through the hold coil take slightly longer to pick than if picked through the pickup coil.

Figure 97 shows a relay in both a de-energized position and an energized position. When the relay coil is energized and the armature is attracted, the armature pivots so that the end away from the core is moved upward. As it moves upward, it pushes against a pedestal which operates the contact strap of the o/p. This will either open, close, or transfer the contact depending on its type.

#### Wire Contact Relay

The wire contact relay is another very common type of relay found on many IBM machines. It was developed to meet the need for a compact high-speed relay for use on 40 volts D.C. The unit is available in three sizes: 4, 6 and 12 transfer contact positions. A latch type is also available. The use of transfer contacts provides a flexible capacity which eliminates the need for several different relay assemblies having various contact combinations. The relay is pluggable,

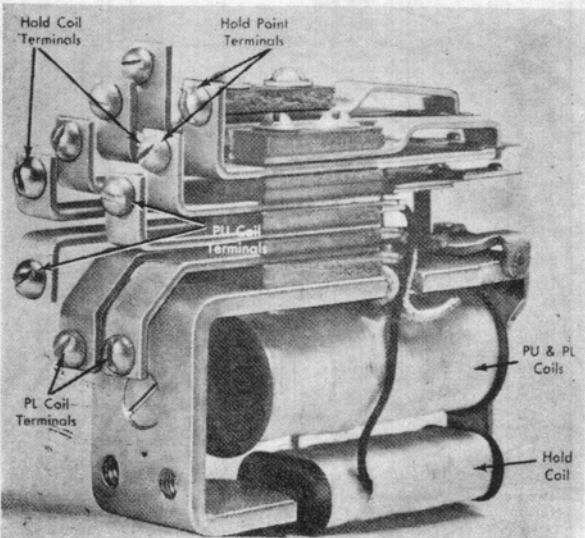
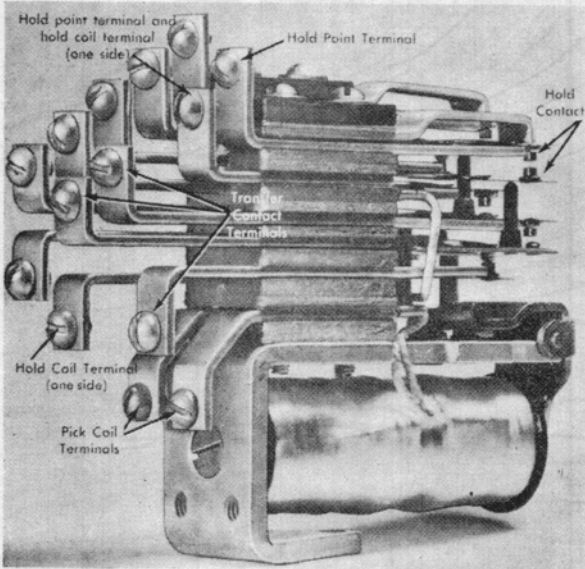
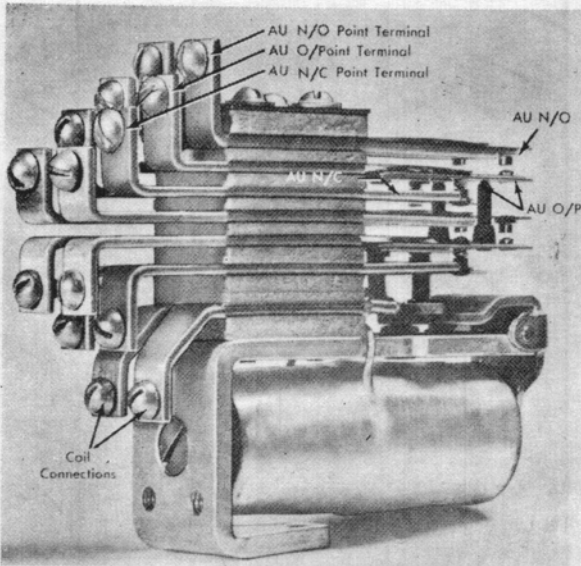

Figure 96. Duo Relay Coil Combinations

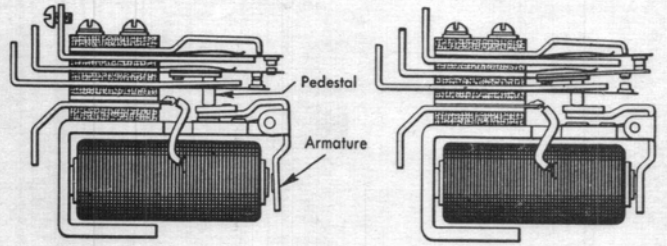

Figure 97. Duo Relay — De-Energized and Energized

employing a terminal moulding connector which permits completion of wiring before the relays are installed in a machine. The unit is readily removable for inspection or replacement and does not require removal of screws or wires.

As the name implies, this relay uses wires as the contacting surface. The wire contacts were not designed for circuit interruption, but the silver alloy now in use will stand some arcing. The wire contact numbering will be from right to left as viewed from the back of the relay. Wire relay points on a wiring diagram are labelled to indicate the relay number and the point number. For example, if the relay number is 45 and it is the third point shown, it will be labeled 45-3.

Figure 98 shows a wire relay in both a de-energized position and an energized position. When the relay coil is de-energized, the wires are making a contact connection between the upper row of terminals and the second row. The upper row terminals are always in contact with their corresponding wires and are referred to as O/P terminals. The second row terminals are in contact with the wires when the relay coil is de-energized and are called the N/C terminals. The third row terminals are in contact with the wires only when the relay coil is energized and are known as the N/O terminals.

Figure 99 shows the wire contact and coil combinations from the terminal end of the relay.

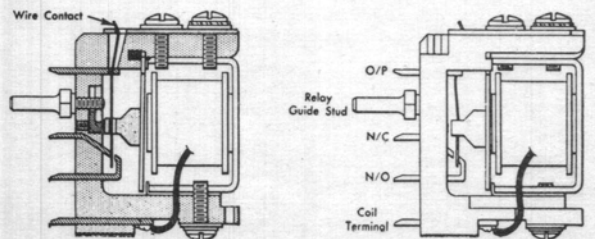
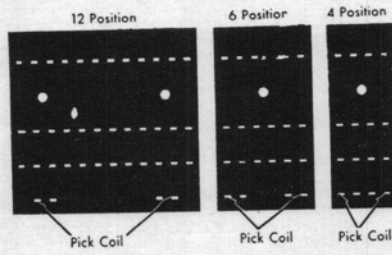
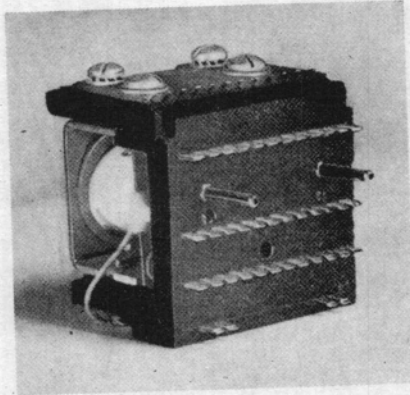
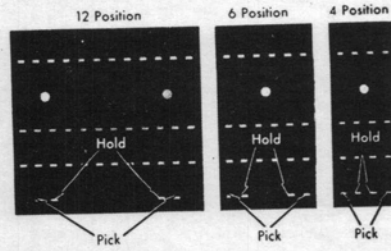
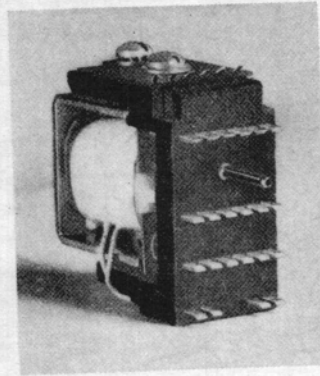

Figure 98. Wire Contact Relay

### Single Coil Combinations



### Two Coil Combinations



### Three Coil Combinations

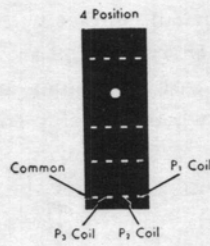
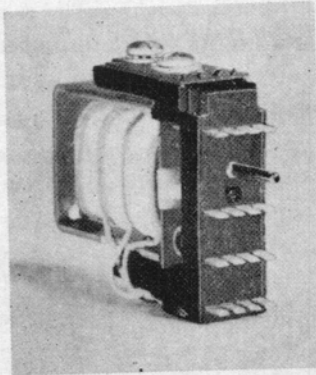

### Latch Type Coil Combinations

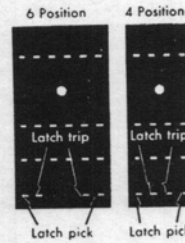
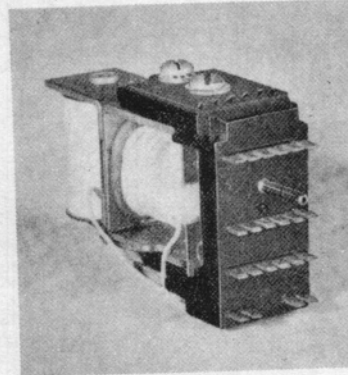

Figure 99. Wire Contact Relay Coil Combination

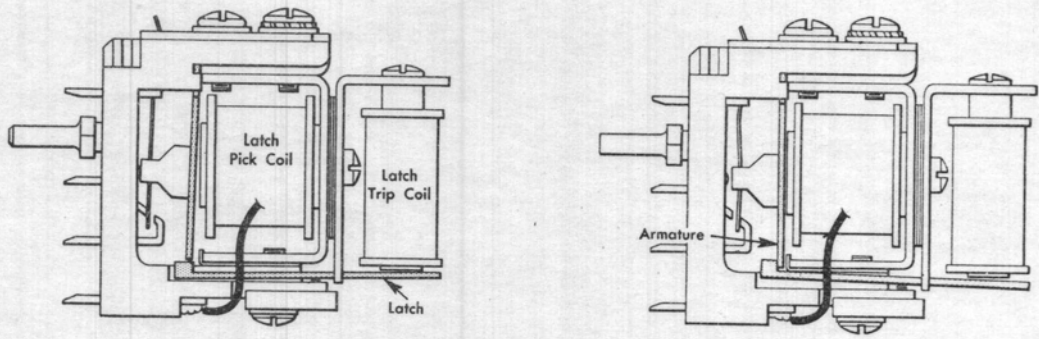

Figure 100. Wire Contact Latch Type Relay

Latch Type Wire Contact Relay

The latch type relay differs from the standard wire contact relay. It does not depend on the continued energization of a relay coil to hold the contacts transferred. Figure 100 shows a latch type relay in both normal and transferred positions. This relay has a mechanical latch that moves up to hold the armature transferred once the pickup coil has been energized. The relay will be held transferred even though the circuit to the pickup coil no longer exists. The latch must be pulled down below the end of the armature when it is desired to have the contacts return to normal. This is accomplished by means of a second coil which has for its armature the right end of the latch. When it is desired to unlatch or return the relay to normal, the latch trip coil is energized.

High Speed Relays

High speed relays are designed to be used where the pickup and dropout times of the duo and wire contact relays are not fast enough to meet machine requirements. These relays will not be studied in detail at this time, but each will be taken up later with the machine in which it is used. Figures 101 and 101A show various types of high speed relays found in IBM machines.

Permissive Make Relays

The trend to higher speed machines has created the need for a high speed multi-contact relay with contact relay with constant tension and no contact bounce. The permissive make relay was developed to meet this need. It will operate in about half the time

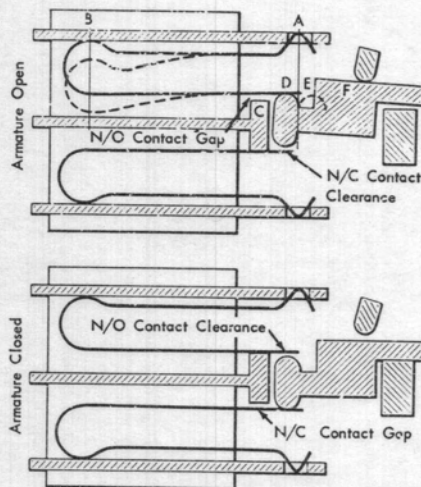
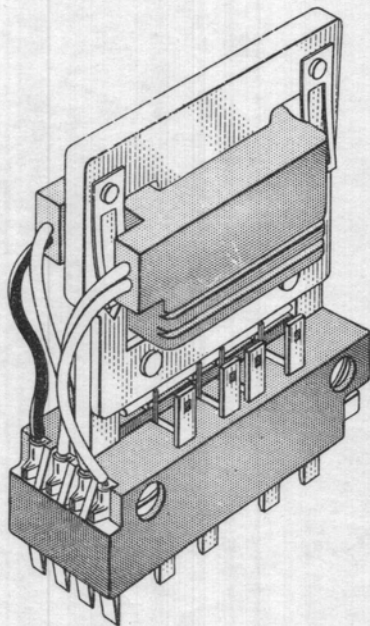
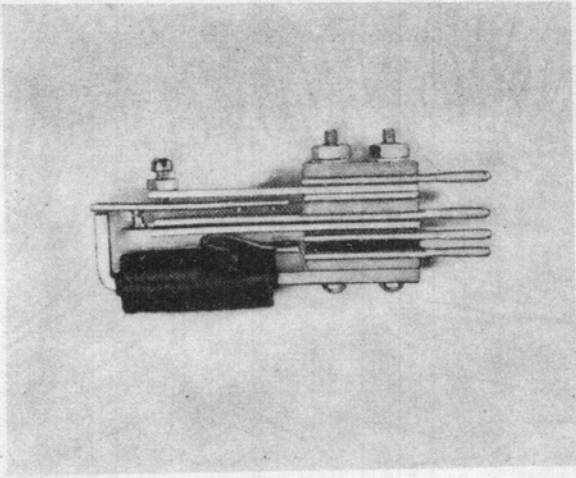
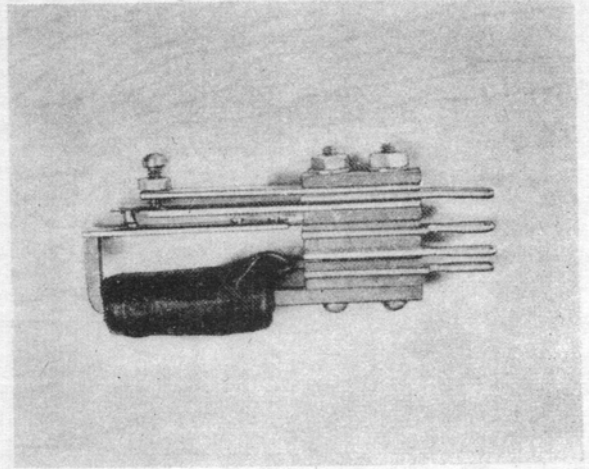

Figure 101. Permissive Make Relay



*N/O High Speed Relay Used in Type 77*



*N/C High Speed Relay Used in Type 77*

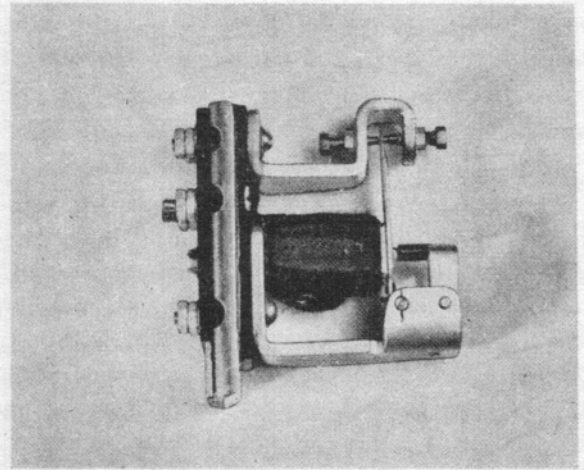
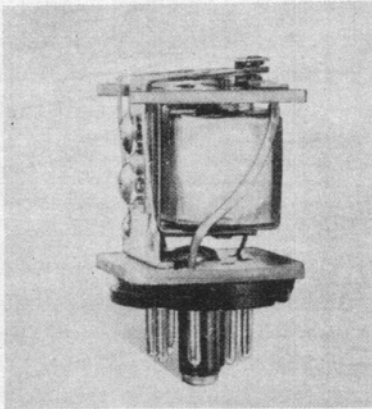

*High Speed Relay Used in Type 402 Accounting Machine*

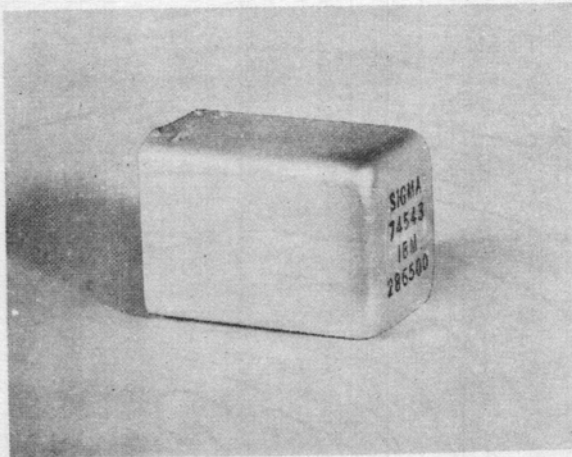

*High Speed Relay Used in Type 89 Collator (Cover Off.)*

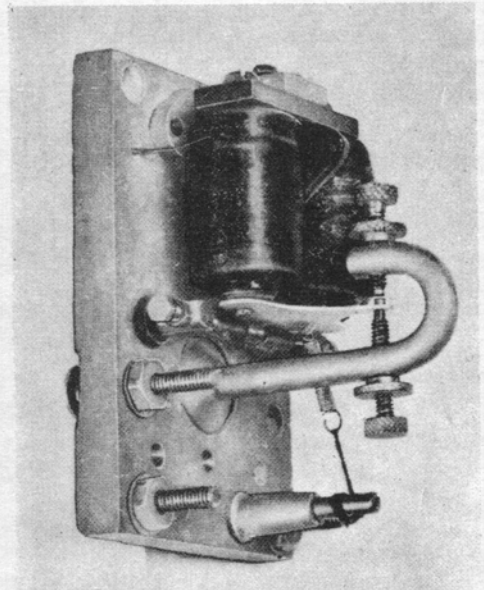

*High Speed Relay Used in Type 80 Sorter*

*Figure 101A. High Speed Relays*

of a wire contact relay and with contact bounce practically eliminated.

This relay is made in 4, 6, and 12 position sizes, and will add color identification to relay gates. The 4 position relay base is red, the 6 position is green, and the 12 position is blue.

The permissive make relay gets its name as the contact being closed is permitted to make by the action of the armature. Each contact position has two sets of wire contacts. One set of contacts is held open by the relay armature while the other set is permitted to make with the contact tension being dependent only on the contact wires. When the armature is attracted, the N/C contact wires are pushed away from the common contact and the wires that had been held open are dropped lightly on the common contact without bounce or oscillation. The contact tension is independent of armature travel.

**CAM-OPERATED CONTACTS**

ANOTHER device used to provide electrical control is a contact which is operated by a cam. The three common types of cam-operated contacts are: rocker arm, plunger, and strap or spring-blade types. The contacts may be used as master timers to provide timed impulses of a definite duration which would be available to many circuits. They may also be used in individual circuits to control the time the circuit is completed (made), the time it is opened (broken), or both.

**Rocker Arm Type**

Figure 102 shows the essential elements of a rocker arm type contact. A rotating cam operating against a cam roller causes the rocker arm to pivot. When the roller passes low dwells of the cam, the contact will be made. The number of times a contact makes during a cycle and the duration of the make are determined by the cut of the cam. For the cam contact illustrated, the contact will open and close twelve times in one revolution.

**Unitized Rocker Circuit Breaker**

A new style rocker circuit breaker is currently being used on some IBM machines. This circuit breaker is similar in all respects of operation to the rocker arm circuit breaker, except that instead of

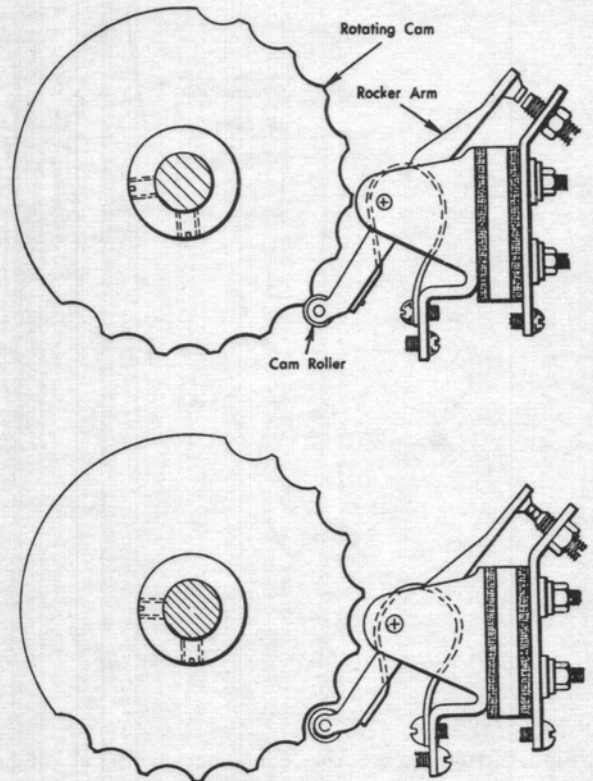

Figure 102. Cam Contact — Rocker Arm Type

being assembled on a bar, it is a complete unit in itself. This makes removal much easier (Figure 103).

Preventive maintenance and adjustments are the same as for the rocker arm circuit breaker.

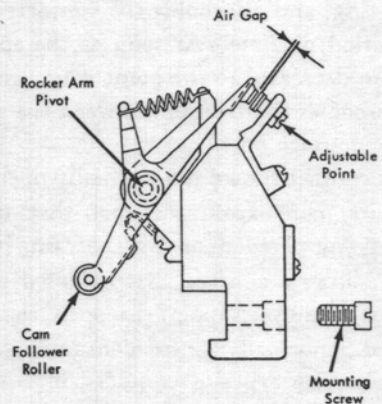

Figure 103. Unitized Rocker Circuit

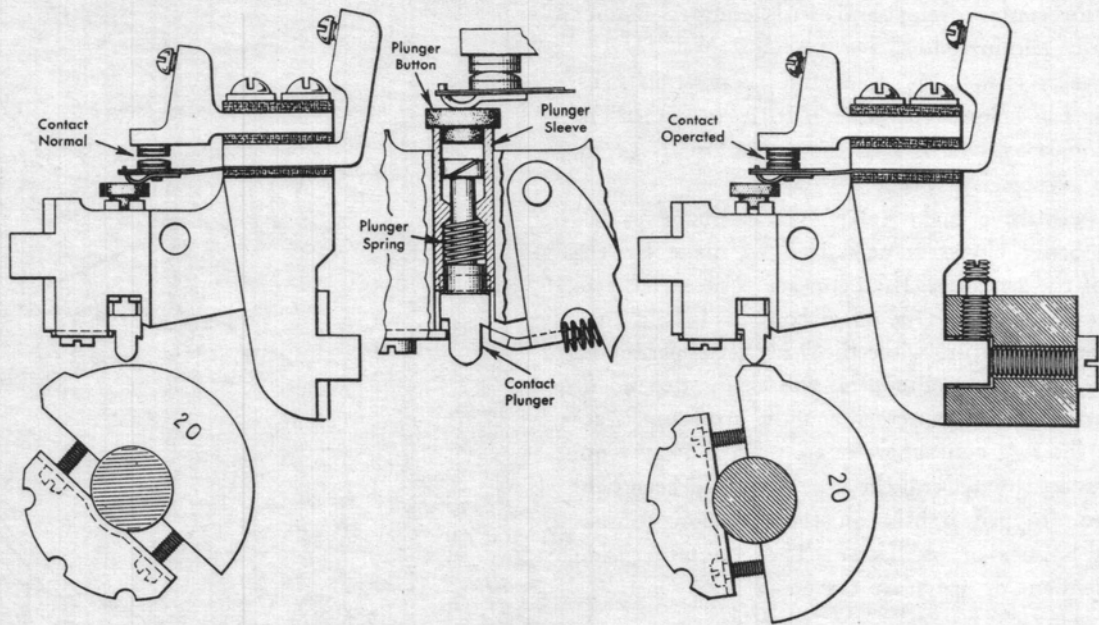

Figure 104. Cam Contact — N/O Plunger Type

### Plunger Type

Figure 104 shows the construction detail of a plunger-type cam contact. The lobe on the cam strikes the contact plunger causing it to move upward. The plunger in turn moves against the plunger spring which applies pressure to a sloping shoulder on the plunger sleeve. The plunger sleeve and button move up together closing the contact. As the plunger continues to move up, it compresses the plunger spring. Compressing the plunger spring increases the contact tension. The plunger spring is pressing against a sloping shoulder of the sleeve, which is in two parts. The two parts are cammed out against the casting. This action creates a slight bind which tends to overcome bouncing, and also holds the contacts made for a longer period of time. As soon as the spring tension has been decreased to the point where the contact tension overcomes the friction between the sleeve and casting, the contact opens.

The cam contact shown is a normally open contact. It derives its name from the fact that unless the plunger is being acted upon by the cam, it is open. Figure 105 shows a contact that is closed unless the plunger lifts the upper point to open the contact; this is called a normally closed contact.

Using these two types of contacts, it is possible to obtain any timing duration desired, with a cam having a maximum high lobe of  $180^\circ$  duration. A nor-

mally open contact is used for all variations of timing up to  $180^\circ$ . For a duration of more than  $180^\circ$ , a normally closed contact is used. For example, a 20-degree cam could be used to give either a make duration of  $20^\circ$  or  $340^\circ$ . The 20 degrees are used to describe the duration of the high lobe which means that they could close a normally open contact for  $20^\circ$  or open a normally closed contact for  $20^\circ$ . There are 41 different cams ranging from  $6^\circ$  to  $180^\circ$  duration of the high lobe. In addition there are cams which are cut with lobes spaced around the entire circumference where impulses at regular intervals are required for more than half of a cycle.

### Latching Plunger Type

There are two other cam contacts which operate on essentially the same basis as the plunger type. The latching plunger type shown in Figure 106 is capable of operating once for each revolution of the cam. The contacts are closed by a lobe on a latching cam which operates on the contact plunger and carries it beyond the latching point of the latch arm. As the latch and unlatching cam continue to rotate, the unlatching cam strikes the latch arm releasing the plunger.

The unlatching cam can be shifted in relation to the latching cam by loosening the set screws which lock the two together. The two clamping screws can



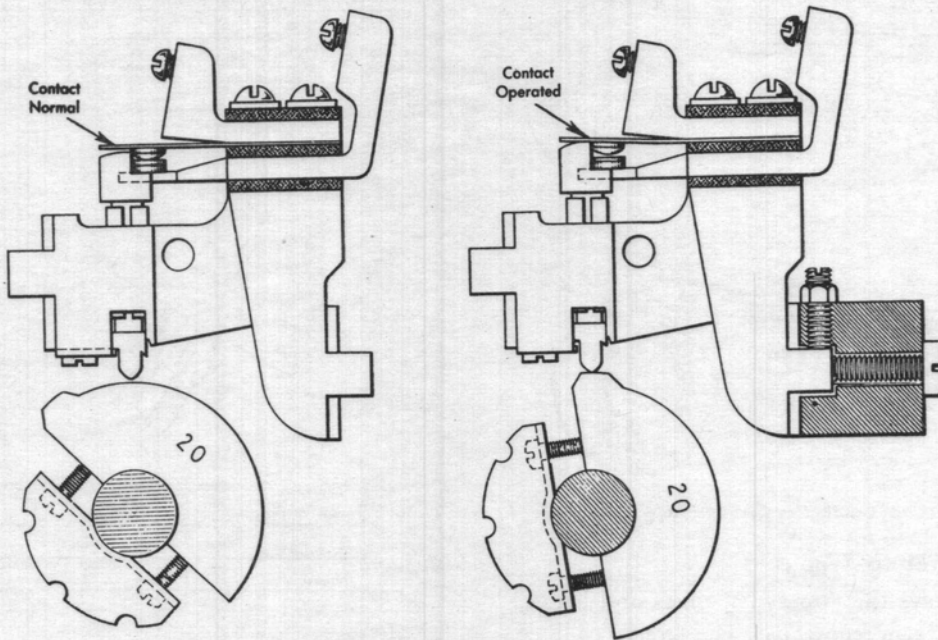

Figure 105. Cam Contact — N/C Plunger Type

be loosened and the latching cam can be rotated on the shaft. In this way any make and break condition can be obtained. The advantage of this contact and cam arrangement is that by means of the one cam assembly all possible combinations of timing may be obtained.

High Speed Plunger Type

The other cam contact (Figure 107) is the high-speed plunger type. The laminated stationary contact and spring cam follower reduce the bouncing of the contact points at high speeds. This construction allows the cam to be used on current machines at speeds of 1200 RPM.

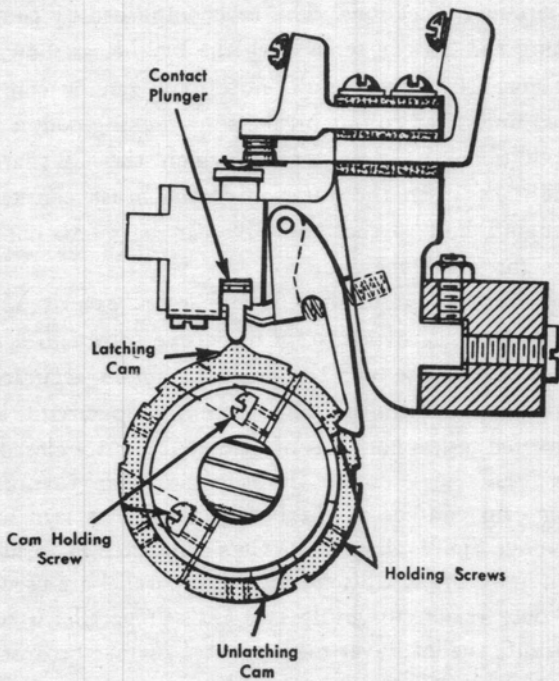

Figure 106. Cam Contact — Latch Plunger Type

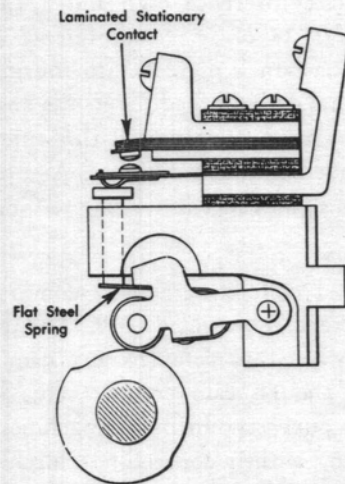

Figure 107. Cam Contact — High Speed Plunger Type

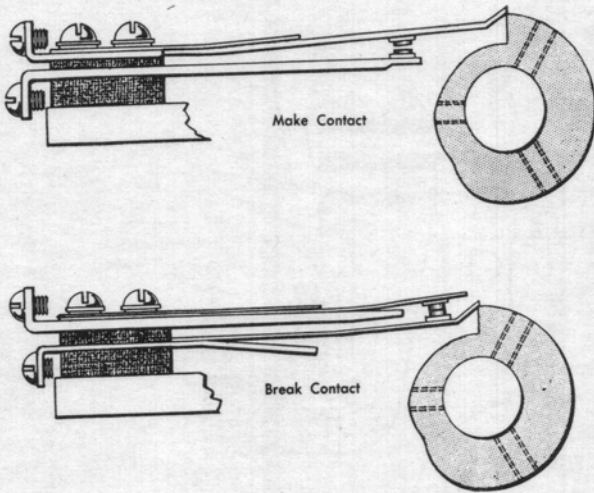

Figure 108. Cam Contact — Spring Blade Type

#### Spring Blade or Strap Type

Figure 108 shows the two types, make and break, of spring blade cam contacts. The break contact points are made while the operating strap is riding on the high portion of the cam, and they open when the operating strap falls off the high portion. Conversely, the make contact points are open while the operating strap is on the high portion of the cam; the points make when the strap drops off the high portion. Break contacts are used where an accurate breaking point is necessary; make contacts are used where an accurate making point is required.

The plastic cams used to operate the contacts are stamped with a fraction indicating the size of the cam. The size is given in fourteenths or a fraction of  $1/14$ , and it indicates the fraction of the circumference that is high. Thus, an  $11/14$  cam has  $11/14$  of its circumference high and  $3/14$  low. A  $1/28$  cam has  $1/28$  of its circumference high and  $27/28$  low. The cam is divided into fourteenths because the original design called for its use on machines employing a 14 point cycle, and at that time the cam sizes corresponded to index division. At present, the cam size has no significance in relation to index points.

#### Circuit Breakers

Cam operated contacts are most commonly used as circuit breakers, abbreviated CB's. The term CB is also commonly used to refer to any cam operated contact, even though cam contacts are frequently used for other purposes. In many machines they are also referred to by their controlling clutch. For example P-cams are under the control of the punch clutch in the Type 513.

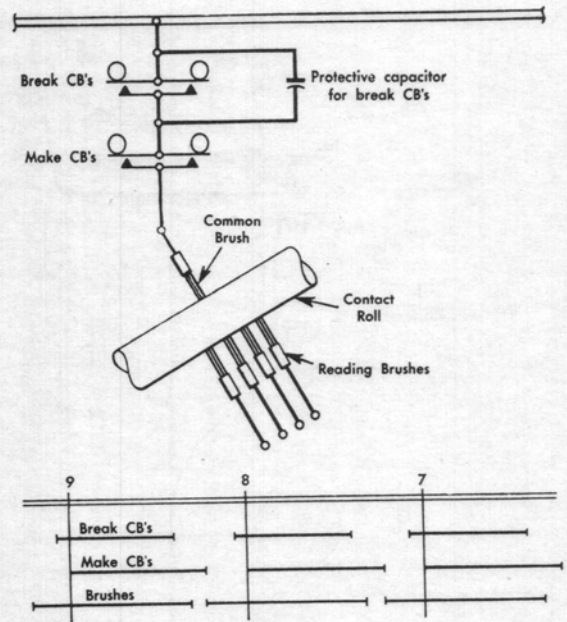

Figure 109. Cam Contacts Used for Brush Protection

The usual purpose of a CB is to provide timed impulses of a definite duration. When a circuit to a magnet is completed or broken, an arc results. Hence, if the brushes are allowed to make and break the circuit connection, arcing at the brushes would result; the brushes would soon be burned beyond use. To prevent this, CB's are provided to make and break the circuit connections. This is accomplished by connecting the CB's in series with the brushes as shown in Figure 109. As a result, no circuit can be completed unless the circuit breakers are making contact. In addition, the time during which the CB's are made is less than the duration of the brush contact through a hole so that the CB's can be set to both make and break the circuit.

Because the cut in the CB cam is not exactly accurate, two sets of cams are used; one to obtain accurate make time and the other to obtain accurate break time. With this offset timing, no circuit is completed unless both sets of cam contacts are closed. This results in a circuit duration less than that of either cam contact or the brush contact, as seen in the above figure. Two make CB's connected in parallel and two break CB's connected in parallel are used. The only reason for using two CB's in parallel is to distribute the load over more contact surface because, even though the contacts are made of tungsten, arcing will burn them.

Because the arc resulting when a circuit is broken is much greater than that caused when a circuit is made, and because the circuit is always interrupted by the same set of CB's, some additional protection is necessary. This additional protection is provided in the form of capacitors connected across the break contacts.

**CAM CONTACTS AND RELAYS IN A TYPICAL CIRCUIT**

FIGURE 110 is an example of how cam contacts and relays might be used to control the energization of a clutch. In this circuit the relay would be energized for one cycle only, unless the start key is held down. As a result the clutch magnet will be energized for one cycle only.

The closing of the start key contact energizes the pick coil of the duo relay. Note that the terminal on the B side is connected to the fuse side of the line. *This*

*is a rule*; however, there are a few cases where it is desirable to reverse the connections. Once the relay is energized the points transfer, closing both the AU and AL points.

The AL point is the point through which the relay will be held energized by means of C1. One side of the hold coil is connected directly to the O/P of the AL contact. The other side of the coil is connected to a terminal on the B side. There is, however, a jumper from that terminal to the B side terminal of the pick coil which connects the B side terminal to the fuse side of the line. The N/O point of the AL contact is connected to the other side of the line through cam contact C1. Cam C1 is a normally closed cam which will be open for a very short time at the end of a cycle to de-energize relay 1. The hold circuit is established as soon as the points are transferred and is as follows: positive line, through C1, through R1AL N/O, through the hold coil, through

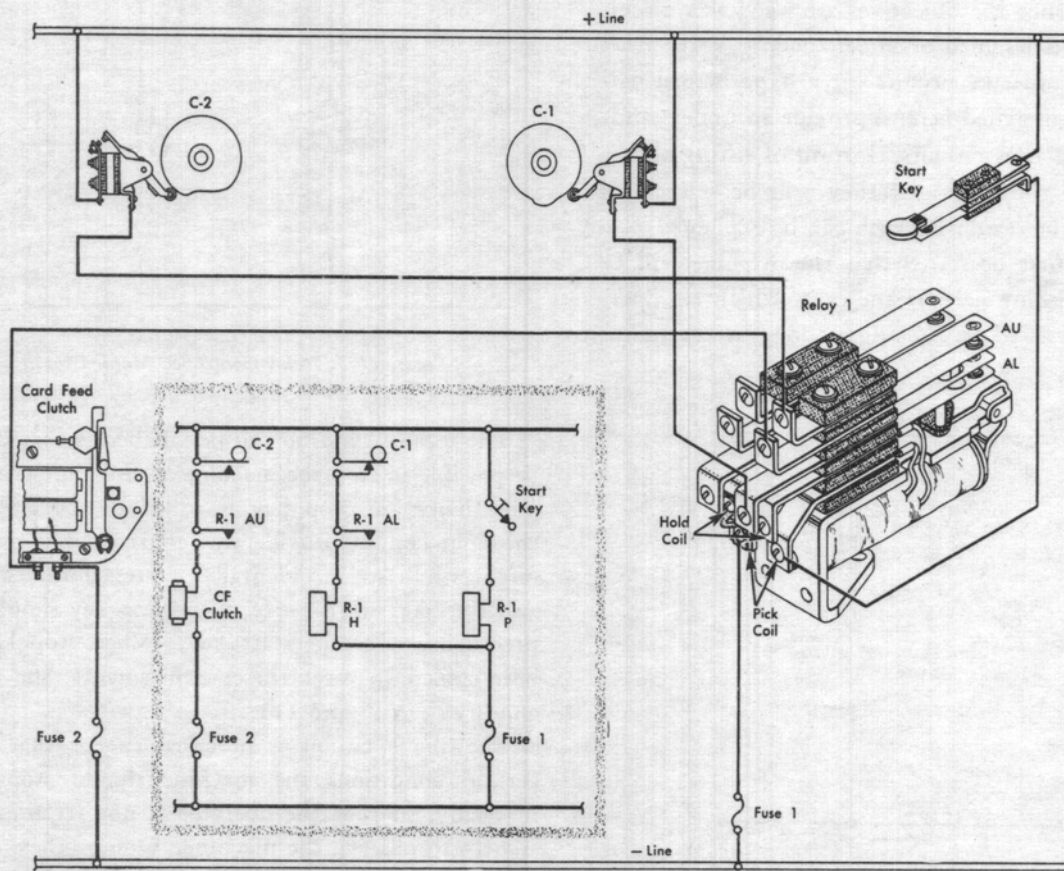

Figure 110. Theoretical Circuit Using Cam Contacts and Relays

the jumper to the pick coil (as a terminal only), to fuse #1, to negative side of the line.

It should be understood that, while a relay point is mounted on the same frame as its coil, there is not necessarily any electrical connection between the point and the coil. A relay point may be used in a circuit which is far removed from the physical location of the relay. On the wiring diagram, relay points are drawn near the units which they control.

R1AU point is an example since it energizes a clutch magnet which is physically located at some distance away from R1. C2 completes the circuit to the clutch magnet through R1AU. The R1AU point will be shown in the clutch circuit which may be located anywhere on the wiring diagram. The inset in the figure shows these circuits as they would appear on a wiring diagram schematic.

Circuit Design and Analysis

Before a circuit can either be designed or analyzed, it is necessary to know the circuit requirements or objectives. Once the objectives are known, a circuit can readily be designed or understood.

The start and run circuits for a hypothetical machine will be designed here to provide an understanding of typical IBM circuits. Instead of listing all the objectives of these circuits, they will be stated one at a time so the reason for each can be explained.

It should first be stated that the machine will be operative (feeding cards); the cams which are operating contacts will be turning, as long as the motor is running.

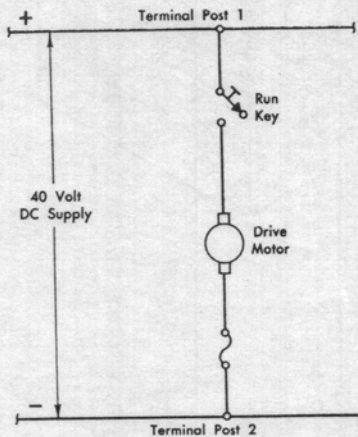

Figure 111. Key Controlled Motor Circuit

The first objective then is to provide a means of energizing the motor. A circuit could be used that would only have a motor and a key contact for components as shown in Figure 111. This circuit, however, could be operative only as long as the operator held the key contact closed, which would be an unsatisfactory condition. A circuit with a relay point in series with the motor is used so that the operation is automatic once it has been started. It is now only necessary to control the time that the relay is energized and de-energized. Figure 112 shows a circuit using a relay to control the motor. The start key is used to energize the relay, but once the relay is energized it holds continuously through its own A point. With this condition, it would be necessary to remove the power from the machine to stop it. If the above were the only requirements of the circuit, a switch controlled by the operator would be a more simple solution.

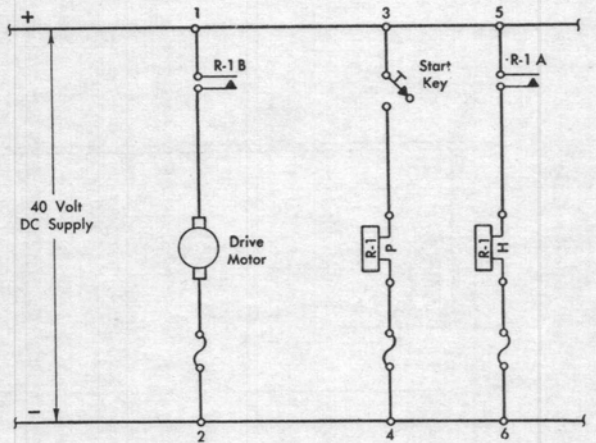

Figure 112. Relay Controlled Motor Circuit

The second condition to be satisfied is that it must be possible to stop the machine at any time the operator desires. A stop key is added in the circuit to the hold coil to provide this control. The operator might, in haste, accidentally depress both the stop and start key so, for safety, the stop key should take precedence over the start key. When stop key has been added to meet these requirements, the circuit appears as in Figure 113.

The above circuit is practical except that under certain conditions the machine should stop automatically, so that the operator is not required constantly to observe the machine. One of these conditions is when the stacker becomes full. If the ma-

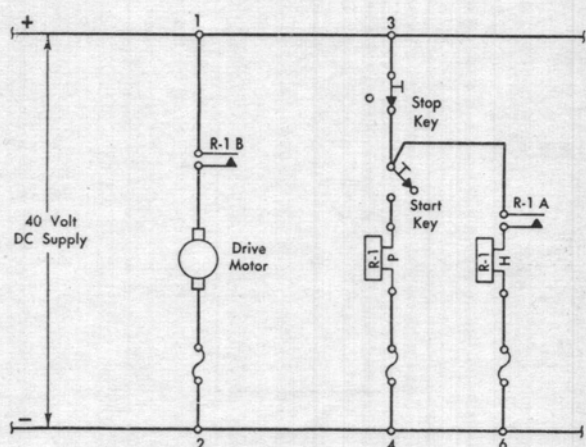

Figure 113. Stop Key Control

chine continues to run while the stacker is full, the cards will jam, destroying a number of cards and possibly damaging the machine. A contact is placed in the stacker to recognize when the stacker becomes filled. Figure 114 shows a stacker stop contact. It is placed in the existing circuit to stop the machine when the contact opens. It is placed in the circuit to hold R1 energized.

In many cases it is necessary for cards being processed to feed successively. This is required for purposes of control, which will be studied with the individual machines concerned. To accomplish this,

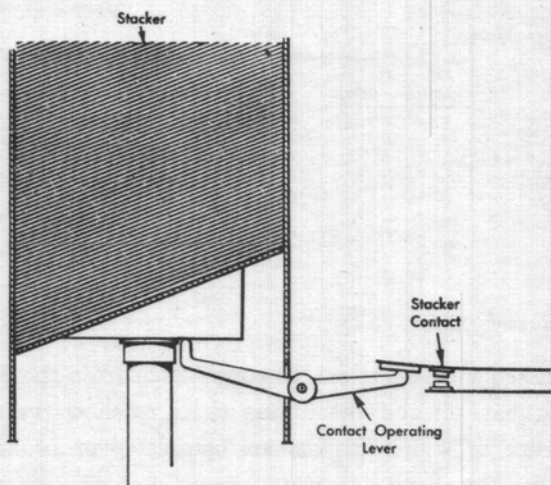

Figure 114. Stacker Stop Contact

it is necessary to stop the card feed unit from operating as soon as the hopper becomes empty. This permits the operator to place more cards in the hopper so that the succession of cards is not interrupted.

Recognition of the time the hopper becomes empty, is easily accomplished by means of another contact operated by a lever similar to the one operating the stacker stop contact. The lever is located in the hopper and is a normally open point, closed only as long as there are cards in the hopper. It is placed in the circuit which is associated with the R1 hold coil only. This is done because it is necessary for the operator to be able to energize R1 and run the cards out of the machine with the start key. Figure 115 shows how both the stacker stop and hopper contacts are added to the circuit to meet these requirements.

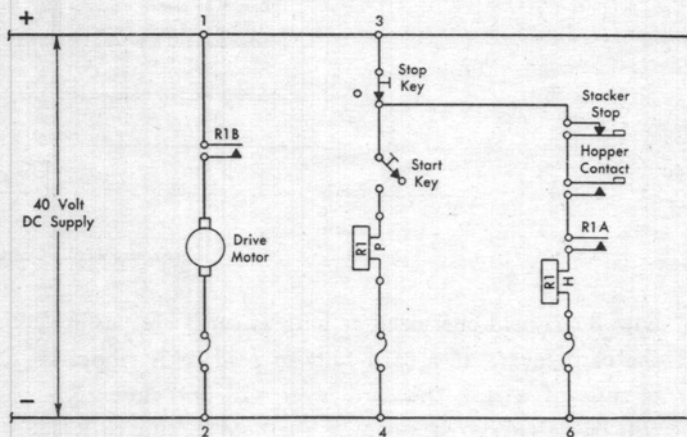

Figure 115. Circuit with Stacker Stop and Hopper Contacts

It is also necessary to recognize when cards are not feeding even though there may still be cards in the hopper. This may occur because a card failed to enter the machine from the hopper or because of a card jam. A card jam may destroy a number of cards and damage reading brushes and other machine parts. One or more card lever contacts are placed in the feed to recognize the presence or absence of a card. If the space between cards is small and the card lever is able to span that distance, the card lever contact will not open while cards are feeding. In this case the contact could be placed directly in the hold circuit for R1. However, in many cases the space is too great for the card lever to span; as a result an arrangement such as the one shown in Figure 116 is needed. The sequence chart and the explanation in the figure show

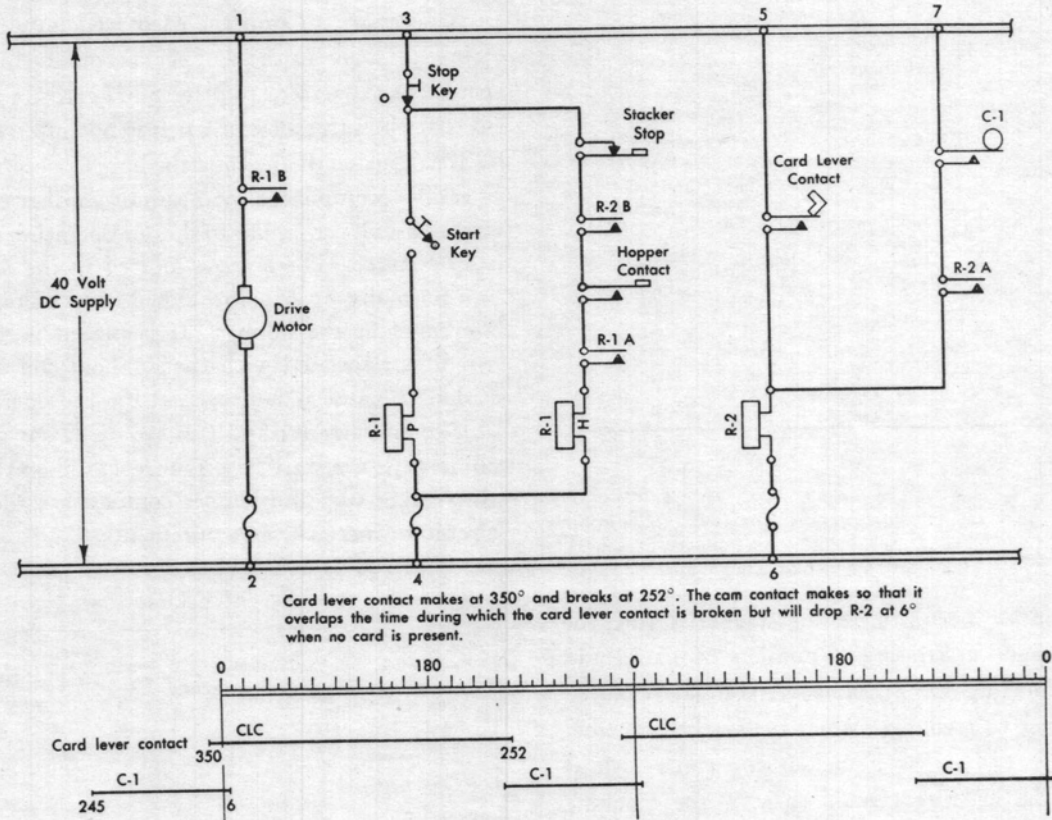

Figure 116. Completed Circuit

how R2 is held energized as long as cards are passing the card lever. If a card fails to feed or is stopped because of a jam, the card lever will not close. R2 will be de-energized, opening the hold circuit to R1, thereby stopping the machine.

If this circuit existed on a machine, to analyze it the approach would be similar to the method used in designing the circuit. It is necessary to know the requirements of the circuit before it can be designed. It is also important that the requirements be known in order to facilitate circuit analysis.

Timing Chart

There are three aids generally used to assist in circuit analysis which are: 1) timing charts, 2) sequence charts, and 3) action and function charts. Timing charts found on the wiring diagram are of two types: mechanical and electrical. They show the time that a specific action occurs during a cycle. The electrical timing chart shows the time in a cycle that each cam contact makes and breaks, also the time card lever contacts make and break. The timing chart in no

way indicates the cycle in which an action occurs. Figure 117 shows a timing chart for the circuit shown in Figure 116. In this case there is only one card lever contact and one cam operated contact, but on a machine many more will be found.

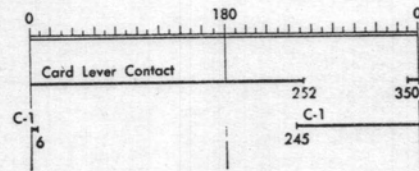

Figure 117. Timing Chart

Sequence Chart

A sequence chart can be constructed from the circuit diagram and the timing chart to show the sequence in which circuits are completed or broken. Figure 118 shows a sequence chart for the circuit described above. To draw this sequence chart it is

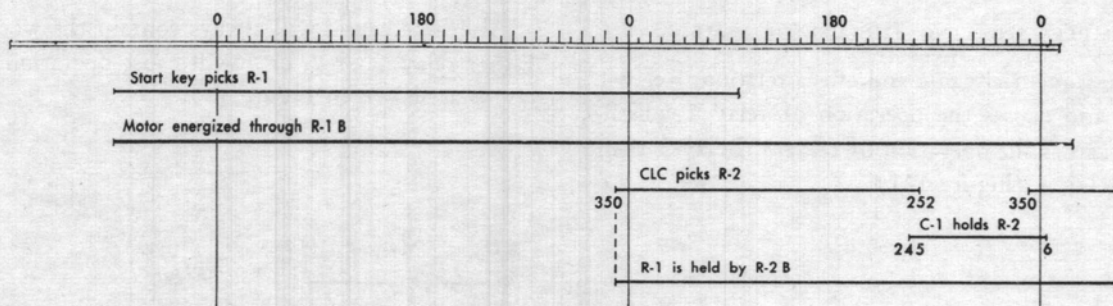

Figure 118. Sequence Chart

necessary that certain initial conditions be known. The machine is not operating and there are cards in the hopper but none elsewhere in the machine. Cards will be fed as a result of the motor operating, and the first card will close the card lever contact during the first cycle. The time that it closes can be determined from the timing chart.

To start the machine, the start key is depressed to energize relay 1. This closes the R1B point which energizes the motor. Both of those actions are indicated by the sequence chart. If the start key was released at this time, or any time before the card lever contact is closed, the machine would stop. This is because no hold for R1 can be established until R2 is picked. However, if the start key is held down until R2 is picked, a hold for R1 will be established. Observation of the circuit will show that if the hopper contact opens because there are no more cards in the hopper, or the stacker fills and opens the stacker stop contact, or the stop key is depressed, the machine will stop. It has been shown also that if a card fails to feed or cards are jammed, R2 will be de-energized, thereby stopping the machine.

To understand a machine completely, both the mechanical action and the circuit action must be kept in mind. A mechanical timing chart is provided to give the time that a mechanical action takes place.

Function Charts

Function Charts furnish a pictorial outline of a circuit function in terms of the relationships required between major components, but, unlike action charts, they do not show the detailed paths of action. The purpose of the function chart is to present on one

page the cause and effect of the more important elements of a given operation and serve as a guide to the understanding of the circuit as a whole. This should materially reduce service time by showing at a glance the highlights of a function without requiring the review of a relay outline or circuit description. It is believed that the function chart should be the first source of information when analyzing an operation.

All function charts begin at the top of the page and read down as time progresses. There is no fixed time scale. Since a function chart is a cause and effect relationship of the various components of a given function, the reader must always proceed to the next lower component and never in an upward direction.

SYMBOLS

There are two basic symbols used in function charts as shown in Figures 119 and 120.

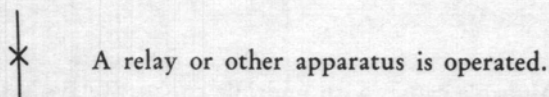

Figure 119

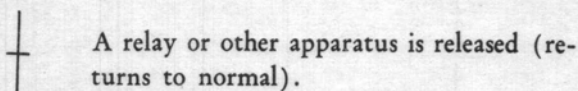

Figure 120

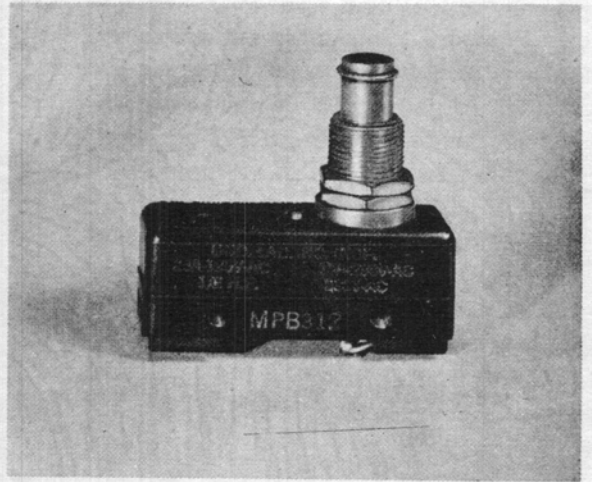
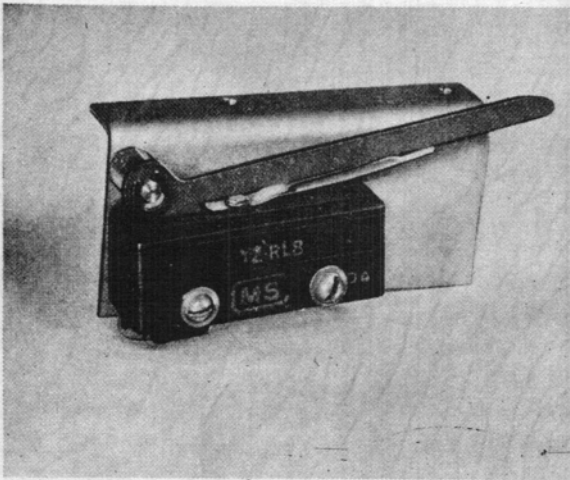
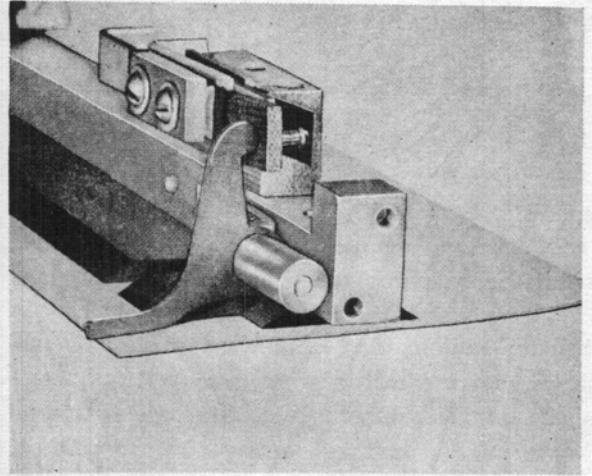
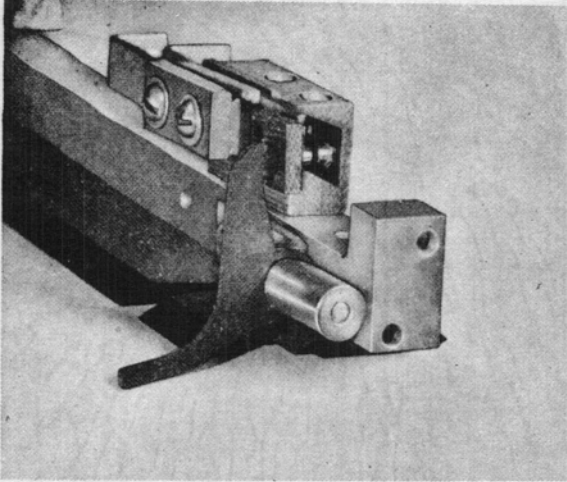

Figure 138. Miscellaneous Switches and Card Lever Contacts



Another type of panel (Figure 136) consists only of hubs into which the external wires are inserted. The wires themselves have longer and larger tips which pass through the control panel and press directly against the stationary prongs, and are known as self-

contacting control panel wires (Figure 137).

Control of the machine may also be obtained by miscellaneous switches and card lever contacts. Figure 138 illustrates a few of these, and they may be operated either automatically or manually.

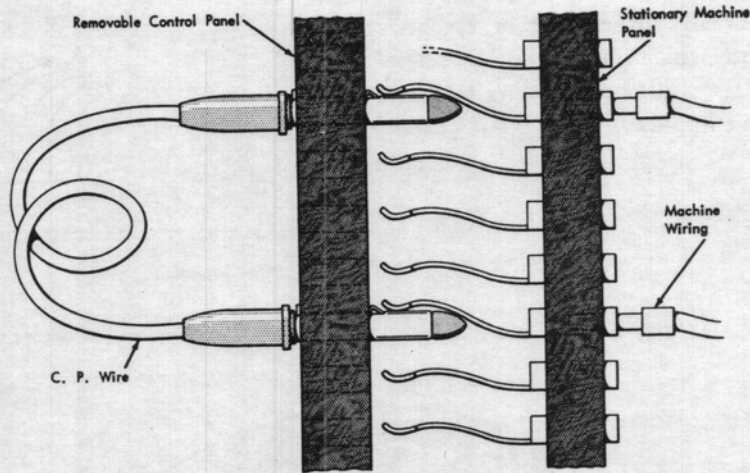

Figure 136. Self-Contacting Control Panel Completing a Machine Circuit

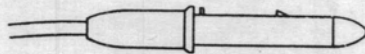

Figure 137. Self-Contacting Control Panel Wire

## CONTROL PANELS

TO PROVIDE FLEXIBILITY, many circuits terminate at a control panel. Figure 133 shows a single panel control panel, wired, and in a machine. The wires serve to connect two or more circuits. Figure 134 illustrates schematically how a circuit from one side of the line is connected to a circuit leading to the other side of the line by means of a control panel wire. Figure 135 shows how the control panel wire physically connects the two circuits shown in Figure 134.

Control panel hubs usually either emit or accept impulses. In general, hubs which lead to the fuse side of the line accept impulses, while hubs leading to the other side of the line emit impulses.

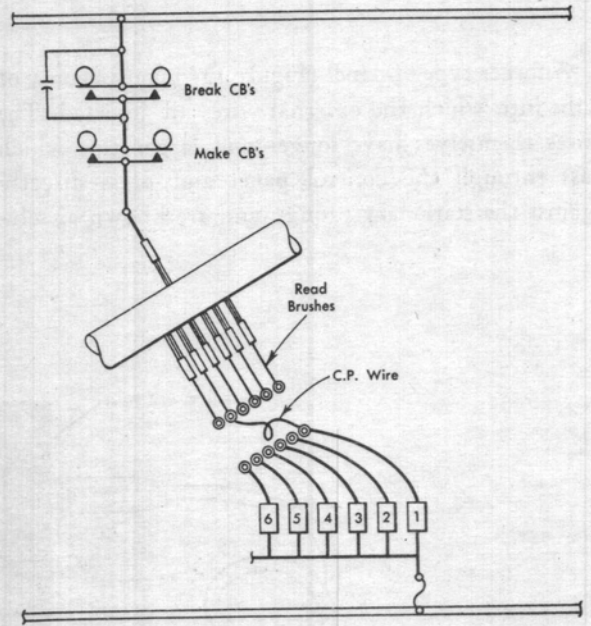

Figure 134. Circuit Completed by Control Panel Wiring

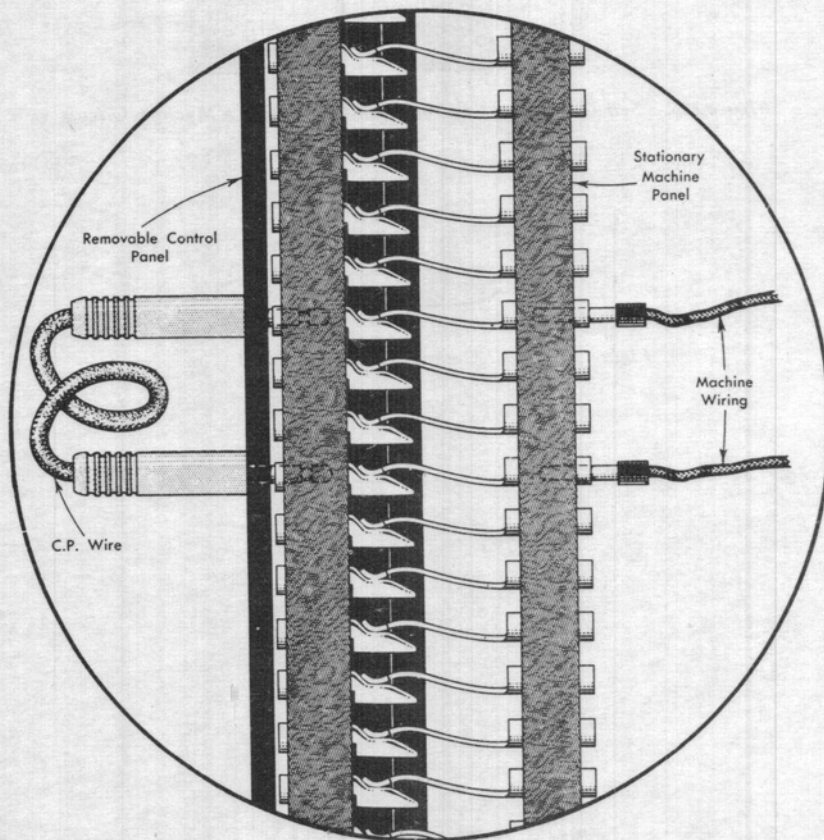

Figure 135. Control Panel Completing a Machine Circuit

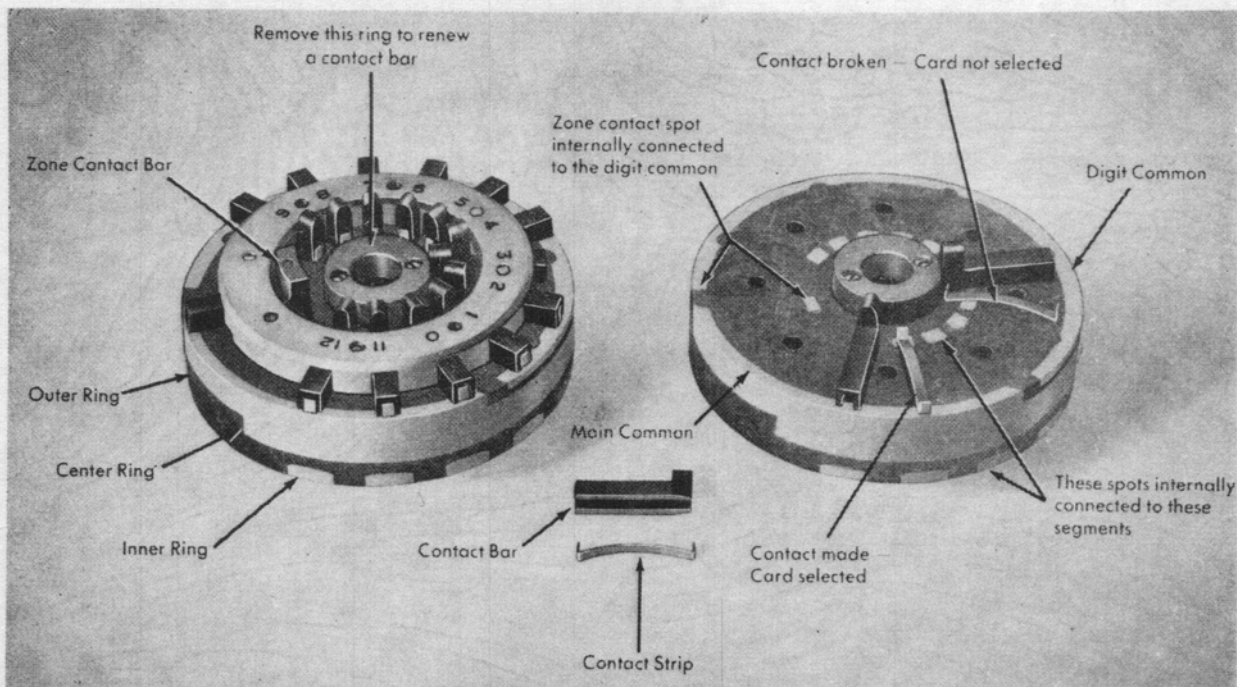

Figure 131. Selecting Commutator

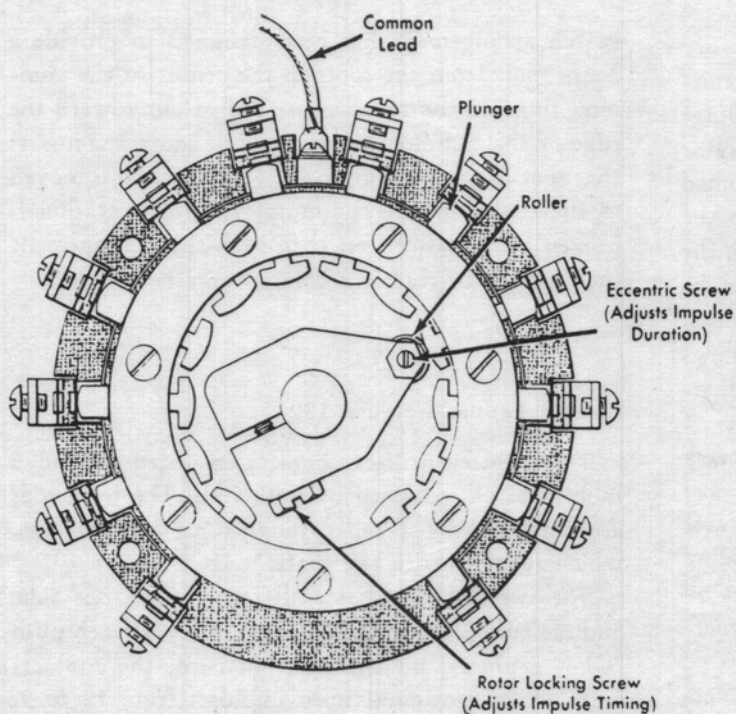

Figure 132. Contact Type Emitter

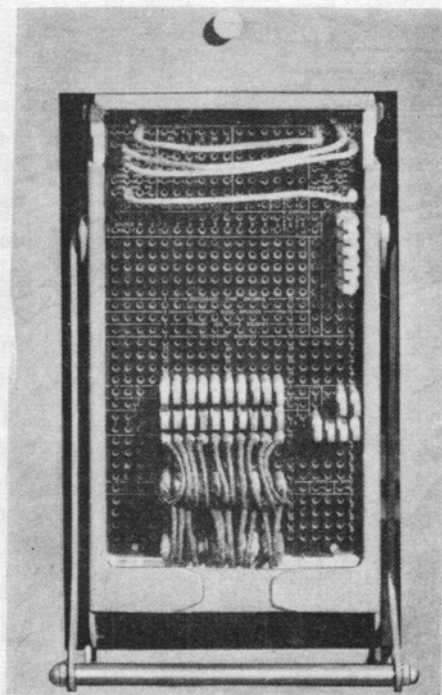

Figure 133. Control Panel

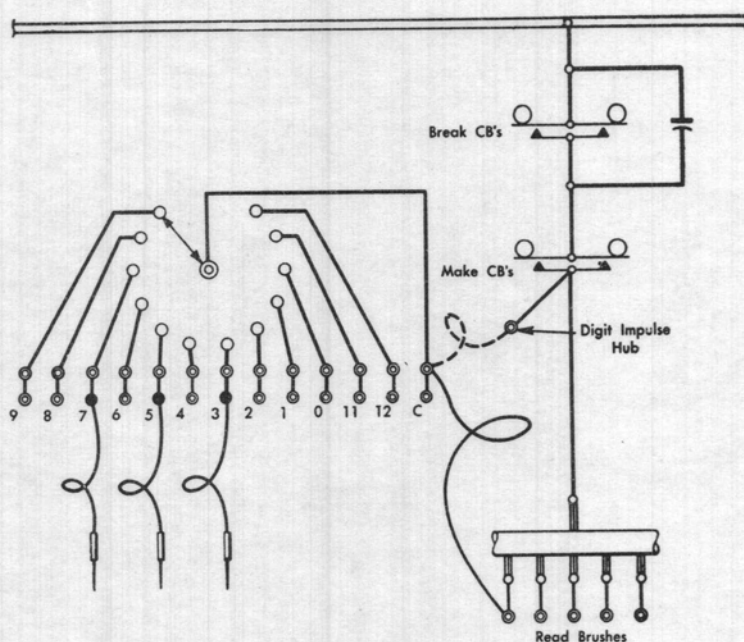

Figure 130. Digit Selector

**Selection Commutator**

The selection commutator is a special type of emitter. The common ring is connected to the voltage supply and the spots are all connected to one wire or circuit. As the commutator rotates, a series of timed impulses are sent out on the one wire. This is the same type of action as that of a CB. However, on the selection commutator the impulses sent out can be selected because the connections between the common ring and the spots are controlled. Figure 131 shows the selection commutator both assembled and disassembled.

On this type of emitter, the brushes are stationary and the commutator ring revolves. The two brushes ride on the outer circumference of the commutator with one brush passing over the spots and one riding over the common ring. A third brush also rides on the commutator to form a hold circuit for the energized magnet.

In the view showing the commutator disassembled, it can be seen that the spots, which the brush contacts, are extended into the center of the commutator. A

switch arrangement has been designed to provide a connection from the spots in the center to the common ring. If the switches are pulled out toward the edge of the commutator, the switch contact connects that spot to the common ring. If the switch is moved to the center of the commutator, the connection is broken. It is easily seen that with this arrangement the digits to be read in a column may be selected.

**Contact Emitter — Figure 132**

This emitter utilizes contacts mounted around a molded block, actuated by push rods. The push rods are depressed by a roller fastened to a rotor arm, which revolves with the shaft.

The twelve contacts are all common on one side, and are connected to the common wire. As each push rod is depressed by the roller in turn, the contacts are closed, furnishing timed impulses from 12 to 9, in the same sequence as the emitter shown in Figure 128.

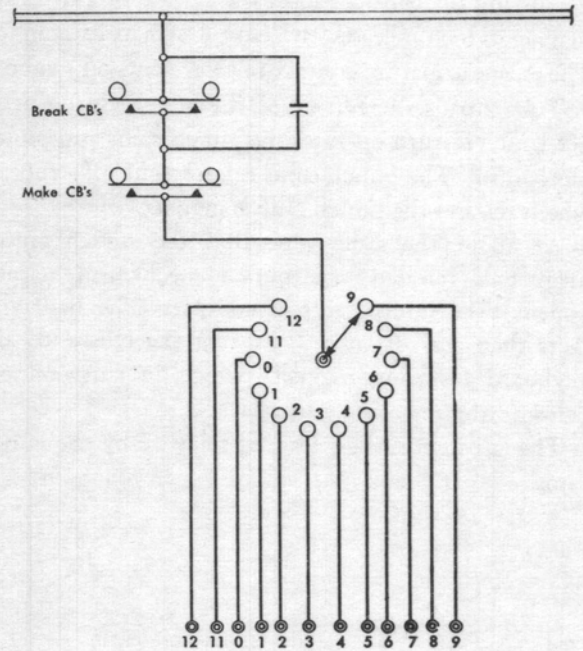
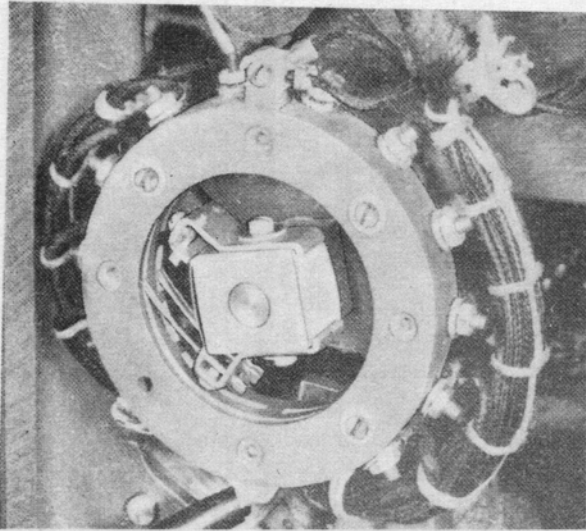

Figure 129. Emitter Circuit

#### Digit Selector

Figure 130 shows a second method of wiring an emitter. When an emitter is wired in this manner, it is referred to as a digit selector. The emitter is more flexible when wired in this manner. If it is desirable to have a digit emitter, the digit impulse hub can be connected to the common hub to make an emitter of the type shown in Figure 129. However, when desired, the common hub can be wired to a reading brush to select digits. The impulse desired can now be selected to perform one or more functions. For example, it might be desired to recognize a card only if it has a 5 punched in a specific column. The brush reading that column can be wired to the common hub; a wire from the 5 hub can be wired to control some mechanism. The mechanism will now operate only when the column being read is punched with a 5. It might be, however, that any one of several punches in the column is to cause some mechanism to operate with each digit controlling one mechanism. For example, a 5 punch could be wired to cause one mechanism to operate, while a 3 punch could control the operation of another mechanism, and a 7 could be wired to control still another mechanism.

The digit selector is completely flexible; any digit or combination of digits can be selected to operate any mechanism.

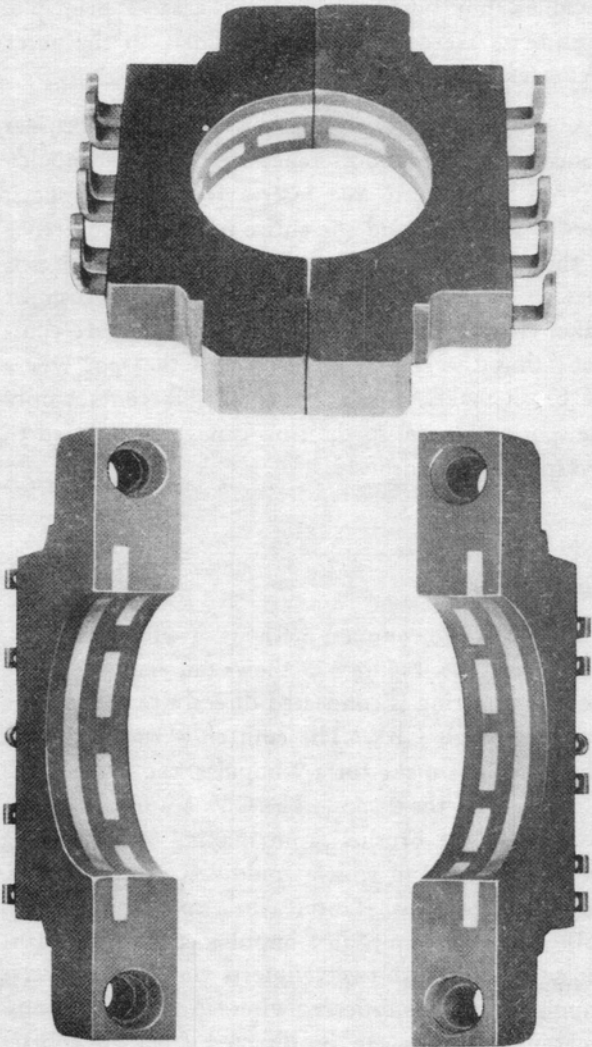

Figure 128. Emitters

Cutting off tube 3 causes the release of the escape magnet which releases the escape armature contact. The escape armature contact releases (cuts off) tube 1.

Tube 7 causes operation of the punch clutch magnet which in turn operates the punch cams and punch mechanism. The punch cams release (cut off) tube 7, which releases the punch clutch magnet.

At about the same time that the punch clutch magnet is released, the punch mechanism releases (opens) the interposer bail contacts. The bail contacts then cut off tube 2, causing the release of the keyboard restoring magnets which in turn releases (closes) the restoring bail contacts.

The last item is the release of relay 22 by the punch cams.

COMMUTATORS AND EMITTERS

COMMUTATORS AND EMITTERS are similar in principle; they differ primarily in the way in which they are used. An emitter is a distributing device that makes available a series of timed electrical pulses. It is electrically similar to an automotive distributor; both send timed impulses to a desired point at a specific time.

In physical construction, emitters consist of metallic inserts moulded or held in a bracket of insulating material. The inserts may be spaced about the inner circumference of a circular moulding or along the length of a flat moulding. The most common type, which will be described in this manual, is the circular type. Figure 128 shows two emitters used on different machines, but both operate on the same principle. The inserts are connected to terminals on the outer circumference to facilitate wiring.

A brush assembly rotates two or more brushes against the inner circumference of the emitter moulding. In addition to the inserts forming the spots, there is a ring around the entire inner circumference of the emitter moulding. One brush or brush set, rides on the ring while the other brush or brush set makes contact with the spots. The brushes are common; thus the ring is connected to the spot where the brush makes contact. The brushes contact only one spot at a time, so the ring is never connected to two spots simultaneously.

Digit Emitter

There are two common methods of wiring an emitter of this type. Figure 129 shows one method where the common ring is connected directly to the voltage source through CB's. The emitter is timed so that when the CB's make for a 9 impulse, the brushes will be making on the 9 spot. The CB's are in the circuit to prevent the brushes from making and breaking the electrical circuit which would destroy the brushes. As the emitter brushes rotate, the 9 spot emits a 9 impulse, the 8 spot emits an 8 impulse, etc. In this manner an emitter with twelve inserts would emit twelve impulses to twelve different wires. Any digit or combination of digits can be directed from an emitter to control an operating unit such as a punching, printing or storage unit.

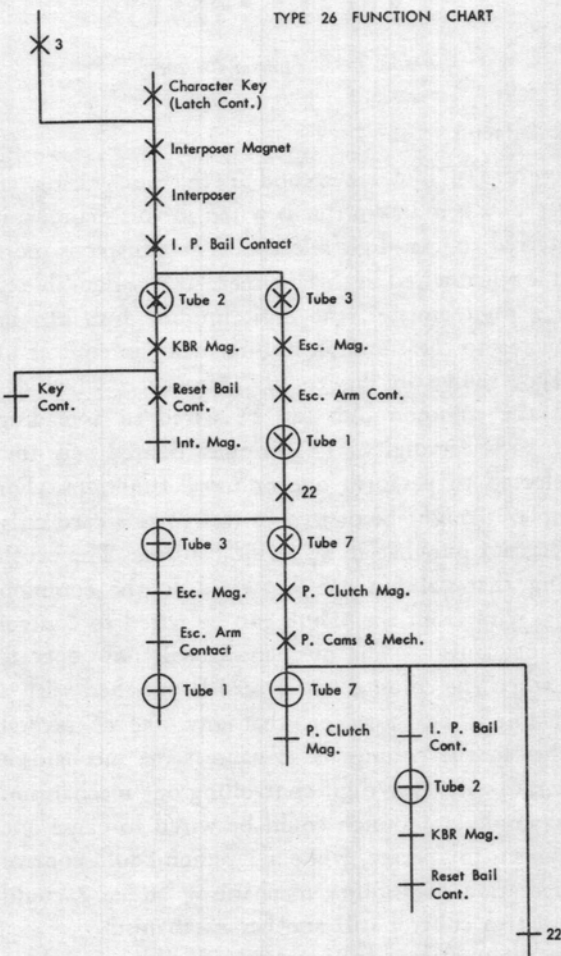

Figure 127. Manual Punching Operation

EXAMPLES SHOWING THE USE OF SYMBOLS

Simple sequential cause and effect relation. Relay 1 operates and causes the operation of relay 2 which, in turn, causes the operation of relay 3. Relay 3 then releases relay 4 (Figure 121).

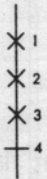

Figure 121

Multiple effects from a single cause. Relay 1 operates and causes the operation of relays 2 and 3 and the release of relay 4 (Figure 122).

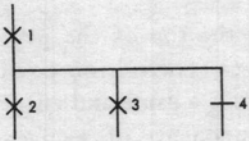

Figure 122

Multiple causes for a single effect. Both relays 1 and 2 must operate before relay 3 will operate as shown in Figure 123.

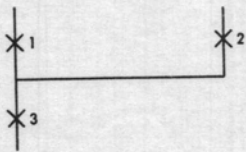

Figure 123

Multiple causes with multiple effects. Relays 1 and 2 must operate before 3 and 4 will operate as shown in Figure 124.

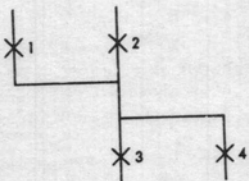

Figure 124

Alternate causes will always contain the word OR. Either relay 1, or 2, or 3 will cause operation of relay 4, as shown in Figure 125.

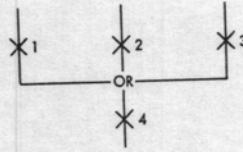

Figure 125

A bracket is used to remind the reader that an element previously energized is needed to cause further action. In the example shown, R20 and R1 are required to cause operation of R2. R1 alone can operate R3. Note that R20 does not affect relay 3 because the bracket enters below the line leading to relay 3 (Figure 126).

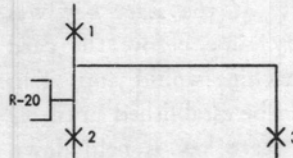

Figure 126

TYPE 26 FUNCTION CHART DESCRIPTION (FIGURE 127)

The following description of the Type 26 manual punching cycle may be helpful in becoming familiar with the charts:

If a character key is closed and relay 3 is energized, the interposer magnet will be operated. This results in the operation of an interposer, which will in turn operate (close) the interposer bail contact. Closing the interposer bail contact causes tubes 2 and 3 to operate (begin conduction).

Tube 2 causes the keyboard restoring magnet to operate; this releases the key contact and operates (opens) the restoring bail contact. Opening the restoring bail contact releases the interposer magnet.

Tube 3 operates the escape magnet which in turn operates the escape armature contact. The escape armature contact operates tube 1 which will cause relay 22 to energize. Relay 22 causes tube 3 to cut off and tube 7 to begin conducting.